

MOUNTY
MUNICIPAL



**Versatile.
Powerful. Agile.**

REFORM 

SINCE 1910

TECHNOLOGY AT ITS BEST



REFORM MOUNTY

The strong and versatile tool carrier.

The REFORM MOUNTY is a tool carrier that was designed with a focus on special tasks. It stands out by its versatility and wide range of use. Cutting edge technology, high operation and driving comfort and best efficiency make the MOUNTY a cherished machine.

The benefits at a glance:

- Hydrostatic drive for continuous transmission of power in any situation.
- Hillholder for stability on the ground in extreme conditions (prevents unintended rolling off)
- 4 steering modes: 4 wheel, front, rear, and crab steering (mirroring possible)
- 3 attachment areas for any use
- Electro hydraulic weight compensation and vibration damping
- Multi-function control lever for intuitive operation (front and rear linkage on one unit)
- Switchable 4 wheel drive (push of a button)
- Preselectable differential locks with 100% locking action on front and rear axle
- Power shift PTO (push of a button)
- Choice between exhaust emission stages 3A and 3B
- Powerful common rail diesel engine
- Sturdy chassis design
- Optimal power to weight ratio with low centre of gravity



The expert in all positions!



Cutting edge technology and safety

The Reform Mounthy chassis.

The Reform Mounthy is a tool carrier for versatile use

The Mounthy is based on a sturdy steel frame structure which ensures high stability in a compact design. This robust system allows to mount a wide variety of attachments, such as extension boom mower, flail mower, snow blower, salt spreader, and many more.

Moreover, this frame is the base for the perfectly tuned attachment of a front end loader.

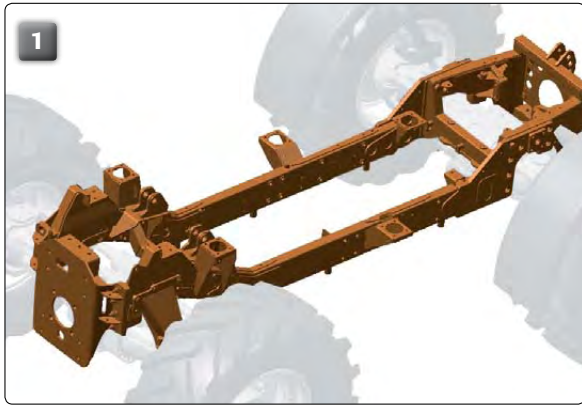

Durable base frame (1)

The continuous steel frame facilitates a compact design, a low centre of gravity and ideal weight distribution. The linkages are integrated in the frame. The steel frame absorbs the forces introduced by the attachments and thus relieves other key components such as engine and axles. This carrier frame is an essential difference to "standard tractors" in this performance class.

2 Direct drive train

The power flows from the diesel engine to the variable hydrostatic pump. The pump is hydraulically connected to the hydrostatic motor, forming a closed circuit. Directly on the hydrostatic motor, the mechanical transfer gear is flanged on, from which the drive power is directly transferred to the wheel driving axles.

3 Front PTO

Efficient use of front attachments with the direct drive train. The engine torque is transmitted by a multi disk clutch which is flanged onto the crankshaft. This design guarantees highest effectiveness and efficiency.



Front linkage without side shift (standard)

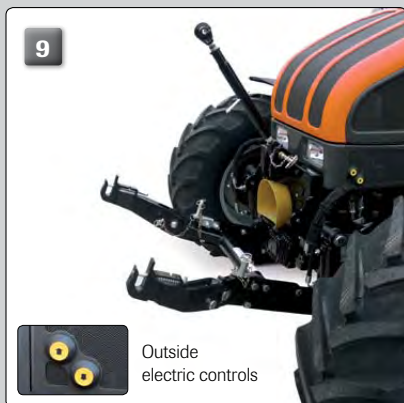

Front linkage with hydr. side shift (option)

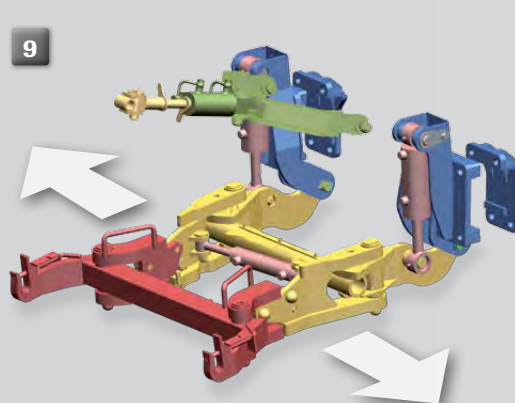

The axle guided **front linkage (9)** with weight compensation and vibration damping guides the attachments exactly and following the soil contour.

The **front linkage can be optionally equipped with hydraulic side shift**. With a total adjustment range of 450 mm, the Mounthy tool carrier masters any task in difficult terrain (slopes, mowing along contour lines). The side shift feature makes mounting tools and working close to obstacles easier.

4 Shiftable four wheel drive

Maximum traction in the field through optimal distribution of the driving power to both axles. With 4 wheel steering activated, the front and rear wheels run exactly in the same track, ensuring absolutely tension free traction of all 4 wheels. For safe parking, the vehicle electronics switches on the four wheel drive when the engine is switched off.

5 Hydrostatic drive

Variable pump and variable motor provide efficient propulsion. 3 electronically defined speed ranges allow stepless adjustment of the working speed to any condition.

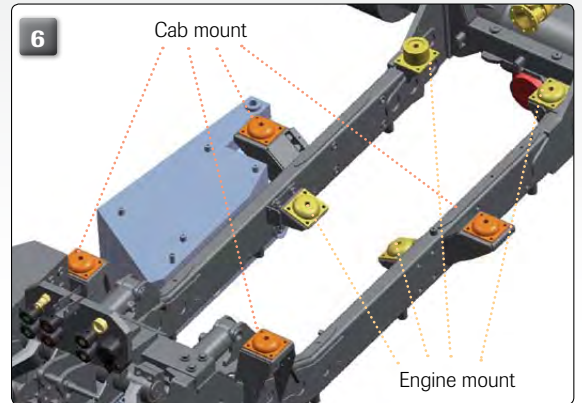

Engine and cab mount (6)

The frame mode of construction reduces the impact of forces on the machine, which can occur by attachments and during road travel. Engine and cab are mounted on silent blocks, actively protecting the driver from high frequency vibrations.

7 Robust driving/steering axles with **planetary gear final drives** provide high towing power and smooth power transmission. The power impact on the drive shafts is lower, which protects the drive train.

8 The **differential locks** at the front and rear axles are switched electro-hydraulically. Both locks have 100% locking action and cope with any situation.

Tank (not shown)

The large 110-litre PE tank holds enough fuel for a whole day's work without refilling.

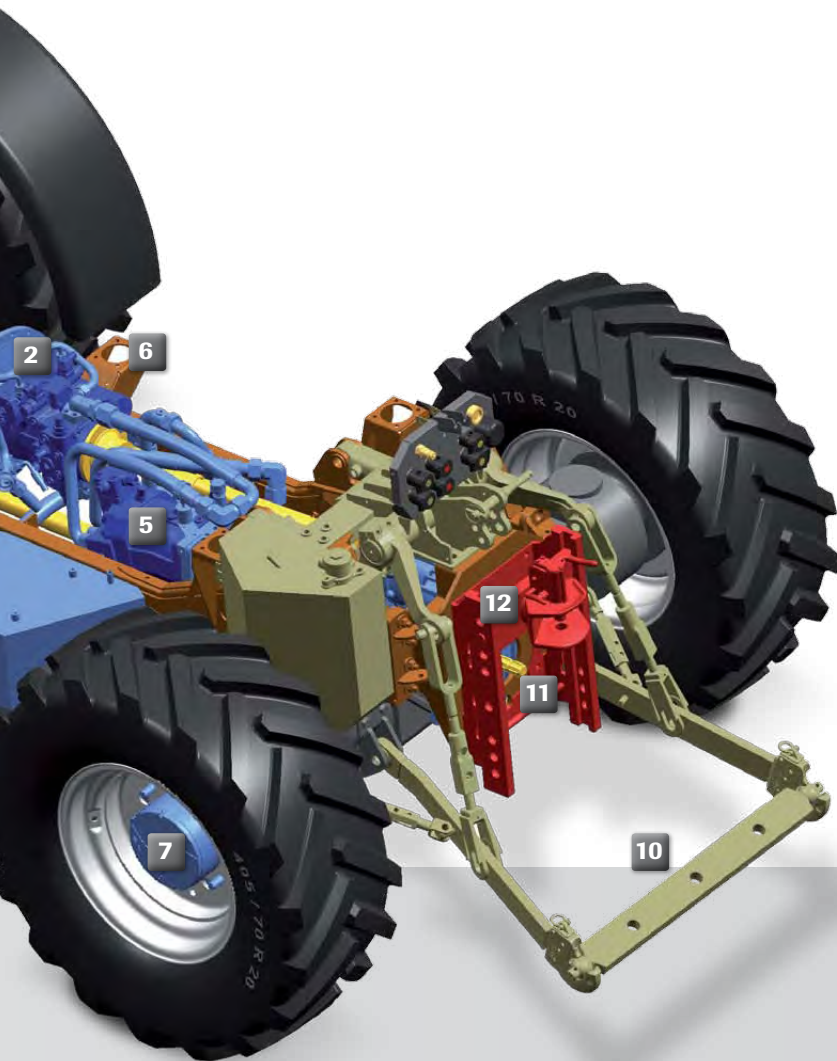

The robust **3 point rear linkage (10)** is equipped with double acting cylinders and lower links with hook ends. The high lifting forces also permits the use of heavy attachments. A particularly helpful feature for mounting attachments conveniently and fast is, as in the front linkage, the standard exterior electric control of the linkages. The linkage is integrated in the frame and equipped with hydraulic vibration damping.

The **rear PTO (11)** (540 or 750 rpm switchable) is electro-hydraulically operated via a multi disk clutch. The soft start feature lets attachments start smoothly every time.

Optionally, various types of **trailer hitches (12)** – fixed or height adjustable on a hitch frame – allow the use of the most various hitch systems. On request, a hydraulic trailer brake system or an air pressure brake system – with or without anti-jackknife brake – is available as original equipment.

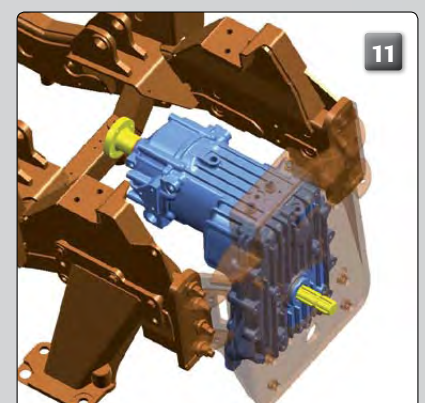

REFORM MOUNTY

3 full attachment areas.

The carrier frame structure of the MOUNTY is designed for accommodating front and rear attachments.

With the additional option of attaching a front end loader, this makes 3 full attachment areas.

The robust linkages with standardised mounting points provide for quick mounting and removing of attachments such as rotary disc mower, flail mower, snow plough, and many others. This makes the MOUNTY your universal workhorse.

1 Front linkage with front PTO

Flail mower, rotary disc mower, twin blade mower, sickle mower, snow plough, snow blower, front road brush, and many more

2 Rear linkage with rear PTO, trailer hitch

3 point linkage mounted sand and salt spreader, extension boom mower, dump bucket, road brush, grass container for sickle mower, trailer, and much more

3 Front end loader

Front end loader with various attachments.



For a wide range of everyday requirements.





1 Mulcher



1 Snow plough
2 Spreader



2 Extension arm boom flail mower



2 E.g. rear weight
3 Front end loader



1 Snow blower



1 Extension arm boom flail mower
2 Hydr. drive unit

Mounty in action all year round

| MUNICIPAL AND INDUSTRIAL | APPLICATIONS | ATTACHMENT |
|---------------------------------|--------------------------|--|
| Green spaces maintenance | Golf courses | Sickle mower |
| | Parks | Sickle mower with grass container |
| | Large areas | Flail and sickle mowers |
| | Road shoulders | Road shoulder mower |
| Forestry | Christmas tree nurseries | Forestry mulcher |
| | Hedge maintenance | Extension boom mower |
| | Forestry | Forestry mulcher |
| Construction and transportation | Transport | Trailer, front end loader, transport box |
| Winter service | Roads | Snow plough/blower, spreader |
| | Parkland | Snow plough/blower, spreader |
| | Ski slopes | Mobile snow gun |
| Lifting | Front end loader work | Front end loader |



Protecting man and machine

REFORM weight transfer and vibration damping.

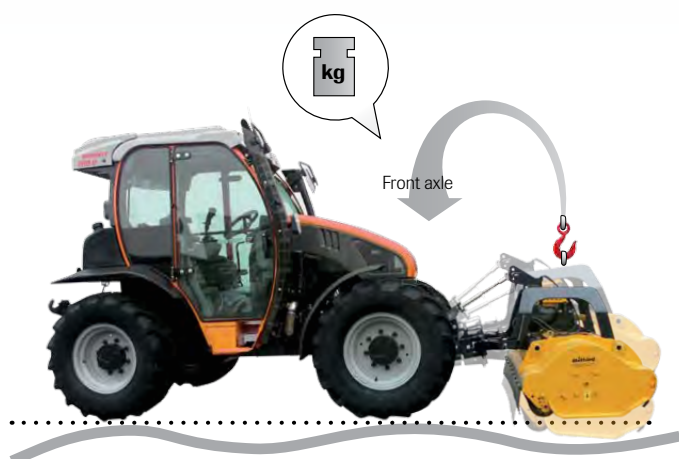

The attachment follows the ground contours without changing the weight compensation pressure

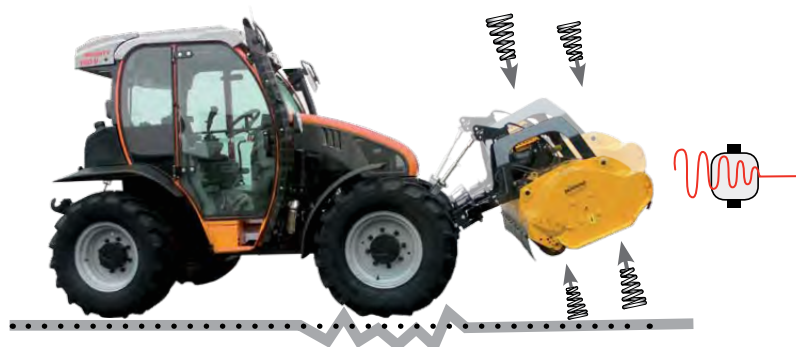

The impact load is minimised by gas pressure accumulators.

Electro-hydraulic weight compensation

The front linkage with electro hydraulic weight transfer allows the driver to control the ground pressure of front attachments conveniently from the cab. The hydraulic system transfers a large part of the attachment's ground pressure to the front wheels using a specified, adjustable residual pressure in the hydraulic cylinders. The attachment virtually hovers above the ground, requiring less pushing force and engine power, gets increased climbing capability and traction, and goes easy on the turf.



The **digital display** shows the set compensation pressure that you pre-select with the push of a button. The electronic system controls the recharging of the accumulators, ensuring that the selected compensation pressure is maintained.

Hydraulic vibration damping

All vibrations caused by heavy attachments during fast driving are neutralised, minimising impact load. This means more comfort and safety, and less wear during work for your Mouty including attachment. The switchable vibration damping (also called vibration absorption) is available as standard equipment for the front and rear linkages.

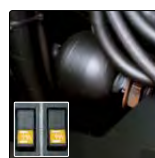

Gas pressure accumulators absorb large part of the vibrations that occur during driving with heavy attachments, especially in road driving.

Your benefits at a glance:

Electro hydraulic weight compensation:

- Increased climbing and slope capability
- More traction through weight transfer to the front axle
- Constant weight compensation for optimal ground following and protection
- Great convenience by easy, straightforward operation
- Weight compensation pressure pre-selectable via buttons
- Setting range from 6 to 120 bar (1 bar increments or quick sweep)
- Permanent desired/actual comparison of the set and the actual compensation pressure
- An indicator light in the dashboard signals when the weight compensation is active
- Protection of the hydraulic system and the machine
- Can be combined with device mounting frame; Precise depth guidance possible (e.g., snow plough on synthetic turf)

Hydraulic vibration damping:

- Provides smooth driving also with heavy attachments.
- Comfortable driving with much more stable driving behaviour and lower machine wear
- Reduces vibration build up in the vehicle during fast road travel with mounted attachment; safety is clearly increased
- Easier travel to and from the work area.
- Forces caused by sudden jolts, which are transferred to the axle by the top and lower links, are reduced
- Damping of vibrations transferred from the ground to an attachment
- Vibrations caused by uneven ground are absorbed
- Damping effect also in the cab
- The vibration damping feature is switchable

REFORM Mounnty

The smart 4 wheel steering system!

Up and down the hills with 4 wheel steering

The hydrostatic steering with four steering modes as standard equipment is the high point in the chassis concept. The steering mode can be switched conveniently with the push of a button, also during driving.

The "thinking" steering

Sensors indicate to the steering control when the wheels are aligned straight, which enables a fully automatic change of steering modes, e.g., from front to 4 wheel steering and vice versa. Easiest operation of crab steering! The desired steering angle of the rear axle is set using a potentiometer, which is then mirrored via levers after turning.

The mirroring of the rear axle steering angle is another essential difference compared to "standard tractors" in this performance class.



The 4 steering modes



1 Front steering

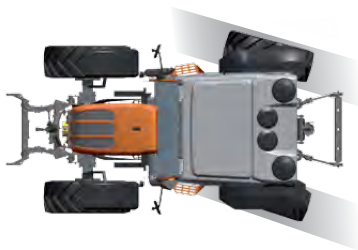

2 Rear steering

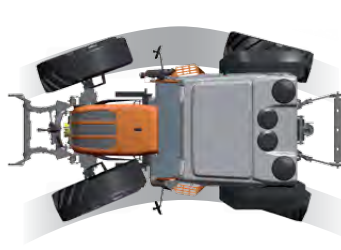

3 4 wheel steering



4 Crab steering

1 Front steering

- For driving on roads, for safe, stable driving at high speeds.
- For working with rear mounted attachments or trailer operation

2 Rear steering

Used mainly on level to moderately sloped terrain. This way, the direction of the front attachment can be better and more exactly controlled than with front steering. Another benefit is that the front attachment is not subject to any side "offset" during steering and therefore can work in a much more steady way.

3 4 wheel steering

The special features of the original Reform 4 wheel steering:

- High manoeuvrability in the tightest of spaces (turning circle \varnothing 6.8 m)
- Front and rear wheels are turned at the same angle and run exactly in the same track.

- Maximum soil protection by even, absolutely tension free traction of all 4 wheels
- Quick and fully automatic switching of steering modes with the push of a button – also during driving
- Better efficiency through shorter turning times

4 Crab steering

Front steering is used while the rear wheels are turned at an angle; this results in a lateral offset during driving.

- For safe work in extreme contours through a shift of the centre of gravity
- Working along ditches and fences; the rear wheels stay at a distance
- Soft ground is protected since each wheel runs in its separate track



Mounty 100 V



REFORM Mounty 100 V 

Hydrostatic drive.

The hydrostatic drive with 3 speed ranges allows continuous adaptation of the **driving speed** to the various working conditions and provides added safety on slopes through permanent power transmission.

Different driving modes for different uses:

• **Manual with the multi function control lever**

Continuous F/R control with stop in the neutral position, for efficient use in partial load operation with low engine speed (e.g. spreader).

• **Automotive via accelerator pedal** for efficient use in the upper speed range with high PTO speed and power needed, (e.g. snow blower, flail mower). This **load limit control** is a special feature of the Mounty 100 V.



Directions can be changed fast yet smoothly using the **F/R shuttle**.

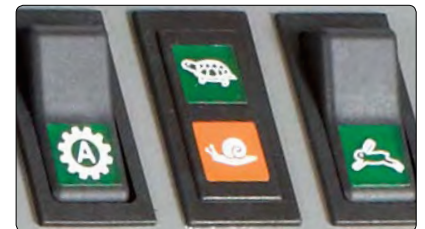

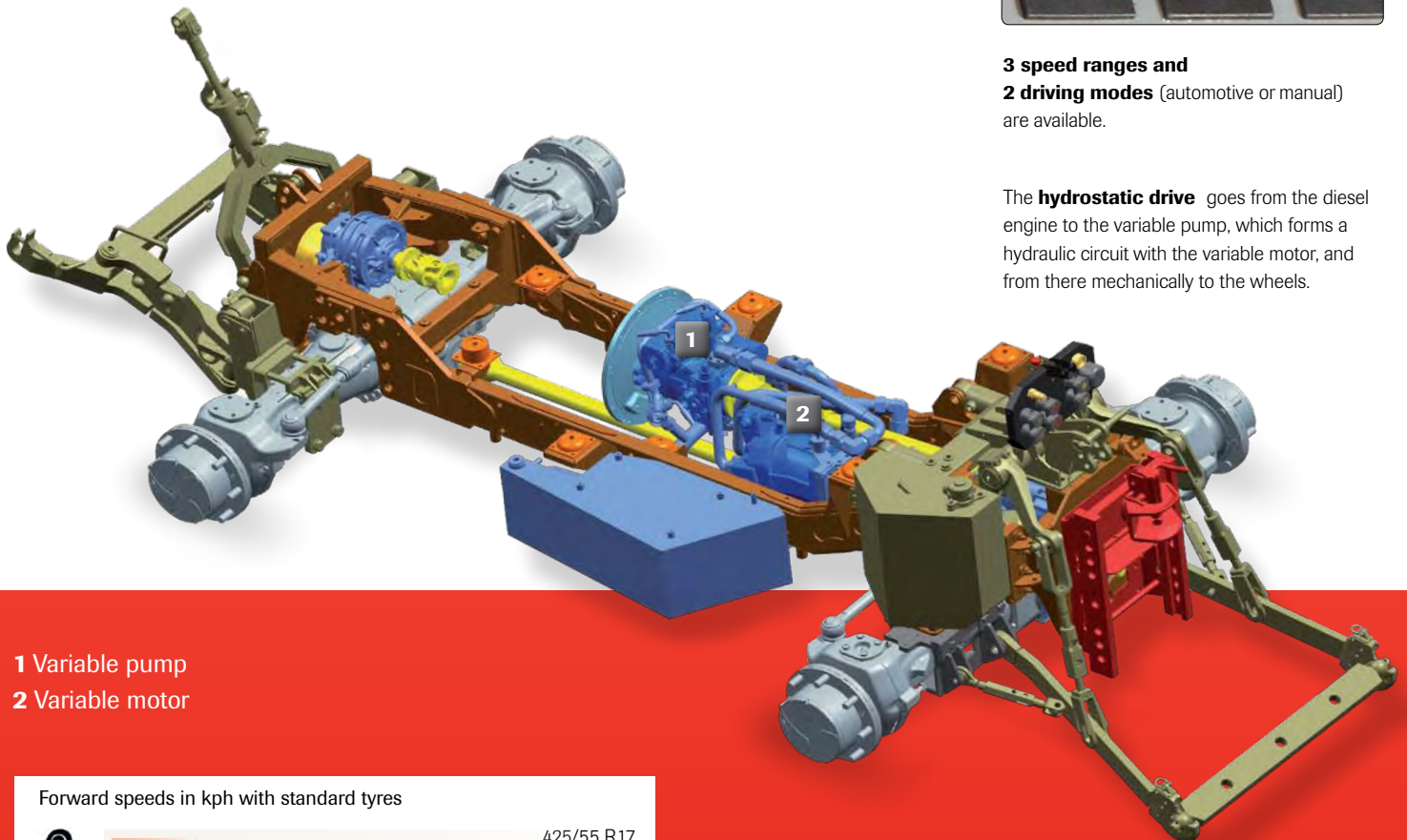

3 speed ranges and 2 driving modes (automotive or manual) are available.

The **hydrostatic drive** goes from the diesel engine to the variable pump, which forms a hydraulic circuit with the variable motor, and from there mechanically to the wheels.



1 Variable pump
2 Variable motor

| Forward speeds in kph with standard tyres | | |
|---|----------|--------|
|  | 1. range | 0 - 8 |
| | 2. range | 0 - 15 |
| | 3. range | 0 - 30 |
| <hr/> | | |
|  | 1. range | 0 - 10 |
| | 2. range | 0 - 19 |
| | 3. range | 0 - 37 |

The benefits at a glance:

- 3 speed ranges for maximum power transmission
- Easy and safe manoeuvring in difficult terrain
- Soft, smooth starting for special protection of the turf
- Continuous speed selection for forward and reverse driving
- Maximum safety on slopes through permanent transmission of power
- Manual or automotive drive mode depending on application
- High working comfort for driver and protection for the brakes
- Inch pedal as active safety device for fast stopping

REFORM Mounty 100 V

The universal tool carrier and a little powerhouse

With the **Mounty 100 V**, REFORM has devised a high performing, comfortable and reliable tool carrier for municipal and other areas of application. Clearing snow in winter, grassland care in summer, transport work with a tipper, loading with a front-end loader – the REFORM Mounty has many uses all year round.

High axle and pay loads enable the Mounty 100 V to heavy work, too, be it in restricted spaces or in extreme terrain. Its outstanding slope capability and soil protection are benefits that have yet to be matched.

A special safety feature of the Mounty is the "**Hillholder**". It keeps the machine in a stable position on the slope, unintended rolling off or back is not possible.



Multi functional operation with one hand

In the Mounty 100 V, the most used hydraulic functions are available simply by pushing a button on the multi-function drive control lever.

You select, stepless and irrespective of the engine speed and under load, the right driving speed and direction.

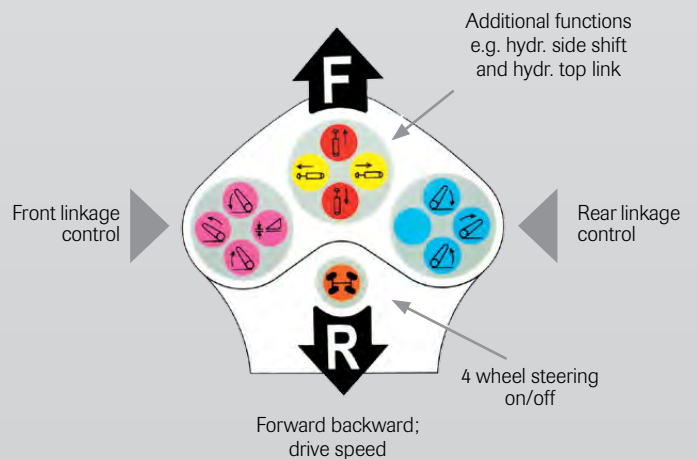

The neatly organised **deluxe cab** with clearly separated indicator and warning lights, provides essential information at your fingertips. The clear and functional layout of the controls provides high driving and operating comfort and ensures that you don't get distracted during driving and can fully focus on your work.



The powerful **cab heating** and the **air conditioning** integrated in the roof provide comfortable conditions both in summer and winter use.



You can work for hours without getting tired with the longitudinally and height adjustable **comfort seats** in different versions.

- Easy care with leatherette cover
- Pleasant with cloth cover
- Comfortable with air damping

Exceptional driving comfort with the electric WIPOMAT swivel unit (optional).



On the **side control panel** you find, clearly arranged and colour coded, further hydraulic functions such as linkage deactivation, weight compensation toggle or oil motor operation (depending on the desired hydraulic system version).

The **hydraulic couplings** of the high performance working hydraulic system are easily accessible and colour coded. Combined with the exterior electric controls of the linkages, this makes mounting attachments "a piece of cake".



REFORM MOUNTY 100 V

Front end loader work like a wheeled loader.

When the **REFORM MOUNTY 100 V** is equipped with a front end loader, you will be able to really appreciate the special qualities of the machine. Hydrostatic drive, F/R shuttle, extreme manoeuvrability due to 4 wheel steering, and the high specification operating comfort make working the front end loader a breeze.

The benefits at a glance:

- Quick mounting and removing
- High ground stability and low centre of gravity
- High performance through outstanding bucket tilt up and large emptying angle
- Front linkage does not have to be removed
- High manoeuvrability through 4 wheel steering
- Exact driving in tiny increments with hydrostat
- Tried and tested frame construction
- The Mounty 100 V forms a unit with the front-end loader
- Exact parallel guidance over the entire lifting range
- Fast motion safety valve for high emptying speed
- Additional hydraulic pump on request
- Level indicator for exact control of the attachments
- Quick release system for quick change of attachments

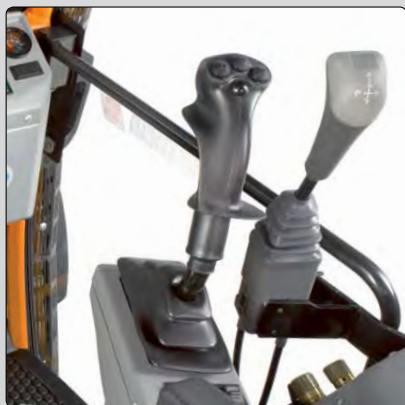

Precise, comfortable front end loader operation

The front end loader can be operated with single lever operation or joystick. This control unit is positioned in convenient reach to the right of the hydrostat driving lever. This ensures the best possible operating convenience, also on long workdays.

Single lever control unit

With the tried and tested single lever control, you can operate the front-end loader's five standard functions without changing your grip.

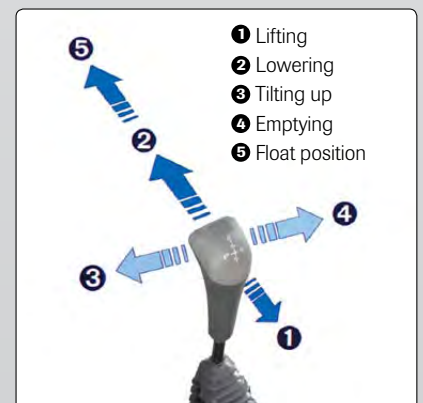



Large tool variety
for a wide range of uses



Bale gripper



Shovel for light materials



Bale fork



Manure fork



Pallet fork



Gravel shovel



Multi hose coupling
Quick and hassle free coupling
of the hydraulic connectors.

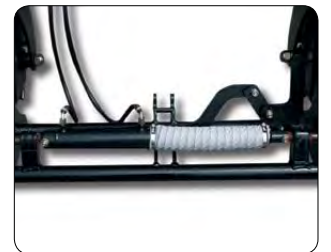

Hydr. tool lock
Quick mounting and removing of
attachments without leaving the cab



Changes of direction are quick and easy
with the **F/R shuttle** while simultaneously
operating the front end loader with your right
hand.

Good view of the front end loader due to
short, dropping bonnet. This ensures exact
loading and precise working with the various
tools.



REFORM MOUNTY 100 V

Know your As and Bs!

In the REFORM MOUNTY 100 V you can choose between engines that comply with the requirements of **exhaust gas stage 3A and 3B**. Both engines have common rail direct injection and are characterised by high torque, reliability and long service life. The high torque in a wide rev range produces full engine power with enough reserves in any situation.



Mounty 100 V
Exhaust stage 3A

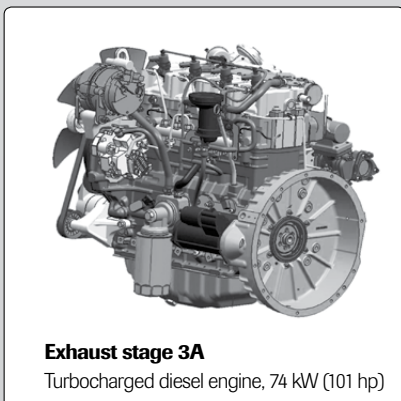

Exhaust stage 3A
Turbocharged diesel engine, 74 kW (101 hp)

The **common rail direct injection** optimises the combustion process and the engine's running characteristics. The required pressure for the injectors is provided in a collective pressure accumulator (common rail). Thus the electronic engine control can choose the moment of injection in an ideal way based on the characteristic maps. This reduces fuel consumption.

Both common rail turbocharged diesel engines have an **electronic accelerator pedal** with a "PTO mode". With this feature, you simply push a rocker switch to pre-select (1) a precise engine speed – especially for PTO operation – and adjust it up and down in increments (2).



Stage 3B – for the sake of the environment

Get the technology of the future now.

As a first in its class, the machine can be ordered already today with an engine of exhaust gas stage 3B.

This engine has been certified according to the current most demanding European exhaust gas standard **EEV (Enhanced Environmentally Friendly Vehicle)**. The exhaust gas stage 3B has certainly been the largest step in pollutant reduction so far, achieved by tried and tested solutions like a **diesel particle filter** and **cooled exhaust gas recirculation**.



Mounty 100 V
Exhaust stage 3B

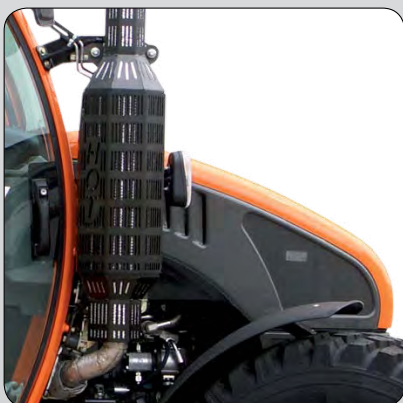

Self regenerating diesel particle filter

The closed loop diesel particle filter system reduces soot emission by over 98%. Furthermore, the system catches and eliminates 99.9% of the particulate matter. The system is completed by an oxidation catalytic converter.

The cooled **exhaust gas recirculation (EGR)** mixes fresh intake air with a certain amount of cooled exhaust gases. The lower oxygen content reduces the exhaust temperature during combustion, which produces less nitrogen oxides (NOx).

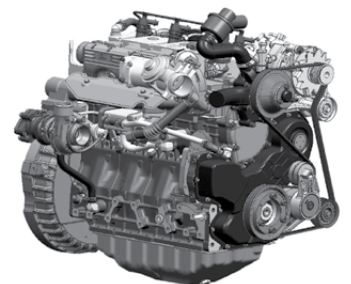

Exhaust emission stage 3B (Euro 5)
Turbocharged diesel engine, 72 kW (98 hp)

Mounty accessories

Top equipment for any job.



Be seen with the removable **rotating warning light** also in poor visibility conditions.



Additional front or rear **working lights** at the cab roof provide excellent view at night and in inclement weather.



With the **hydraulic top link** you can react quickly to uneven ground or adjust the cutting height with the push of a button from the comfort of your cab.

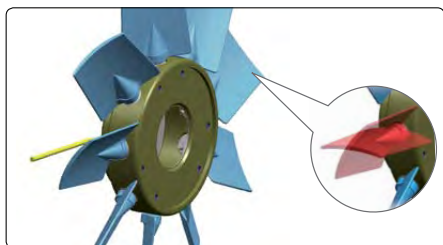

By turning its blades, the fan becomes a **reversing fan** for quick and easy cleaning of clogged fan grilles (also during work).



Front mounting plate for municipal attachments. Attached tools are guided precisely over the front axle (weight compensation).



Unobstructed view through **heated windscreen** and **rearview mirror** in winter service.



Your favourite tunes from a **stereo radio** with CD makes your workday even more agreeable.



A sturdy **protective frame** is particularly useful for special applications, e.g., in forestry.



All Mounty models can be finished in your specified **custom paint**.

Highest towing force with Mounty.



Mechanical or automatic **trailer hitches** are available for different trailer models. They are either fixed or can be height adjusted by a slide, which proves very useful. With a ball coupling, the Mounty can also draw car trailers. The fixed connection of the trailer coupling directly to the frame provides exceptional stability, permitting towed loads up to 10,000 kg (braked).

Installing a hydraulic **trailer brake system** or an **air pressure brake system** ensures high safety when transporting heavy trailers (original equipment only). Air pressure brake systems can be delivered with or without "anti-jackknife brake".



REFORM Mounty

A high profile machine!

Basic tyres*



440/50 R17



560/45-22.5



12.5 R20



405/70 R20



420/65 R20



425/55 R17

A large selection of tyre types with various special profiles provides **maximum traction, low ground pressure, and reliable turf protection**. They provide grip on difficult soils and on steep slopes.

Choose from:

- Narrow tread low pressure tyres for maximum soil protection
- Agricultural tyres for high pulling performance and high stability
- Turf tyres for intensive lawn care
- Road profile

Auxiliary tyres



7.50-18



9.5-24

*Other profiles and tyre sizes on request. This way you can adapt the Mounty optimally to any work situation!

Up the hill with even more grip!

Even better slope capability and soil protection with the **front and/or rear auxiliary tyres**. Quick mounting and removing with quick release.

If you want to mount auxiliary wheels at the front or rear axles, fasteners can be attached on both axles for quick change between front and rear axles.



Innovative engineering since 1910

Customer Satisfaction through Quality.



The REFORM-Werke in Wels is one of the few manufacturers which assume undivided responsibility for the entire value added chain. Have a brief tour on the creation of Reform products, from development of a new machine to standard production. The entire production process is subject to the requirements of the **ISO 9001 quality management system**.

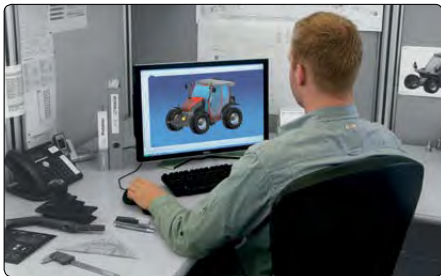

Latest equipment, such as 3D CAD, in **design and development** of new special purpose vehicles.



In **parts production** precision parts are manufactured on leading edge CNC tools in different batch sizes.



Permanent **quality control** ensures compliance with standards according to the ISO 9001 quality management system.



In **line assembly**, highly trained and continuously schooled expert personnel produce a wide range of vehicle types and variants.



Before delivery, all vehicles undergo intensive **functional testing** such as here on the roller test bed (pictured).



In the **end check** and the **finishing department**, all machines are thoroughly checked once more and prepared for shipment to their future owners.

REFORM – On the way to the customer.

A large part of the machines are transported with **REFORM's own lorries** – they reach their destination fast and safely.

Our new transport vehicles in eye catching, cutting edge design. They have special accessories for the optimal loading of REFORM machines. Additionally, we also use outside forwarding agencies and railway transport.





Moutny 100 V

Technical data

**Mounty 100 V
Stage 3A**



**Mounty 100 V
Stage 3B**



| | | | |
|---------------------------|---|---|--|
| Engine (Stage 3A) | 4 cylinder 4 stroke diesel engine, VM-R754 IE 3 with turbocharger, intercooling and direct injection, 74 kW (101 hp), displacement 2,970 cm ³ , water cooled. Torque 340 Nm at 1,600 rpm. Emission standard 3A . | | |
| Engine (Stage 3B) | 4 cylinder 4 stroke diesel engine, VM-R754 EU5 with turbocharger, intercooling and direct injection, 72 kW (98 hp), displacement 2,970 cm ³ , water cooled. Exhaust gas recirculation and diesel particle filter ; torque 340 Nm at 1,400 rpm. Emission standard 3B . | | |
| Gearbox | Hydrostatic travel drive with electronic control, with variable pump and variable motor; 3 speed ranges, electro hydraulically switchable: with tyres 425/55 R17 / 405/70 R20 Range 1: 0 – 8 / 0 – 10 kph Range 2: 0 – 15 / 0 – 19 kph Range 3: 0 – 30 / 0 – 37 kph Hydrostatic control selectable between automotive or manual , electro-hydraulically switchable. Power limit control – constant pre-set engine speed by electro hydraulic speed control, inching pedal, F/R shuttle operation. | | |
| Clutch | Multi disk clutch for front and rear PTO drive, electro hydraulically switchable with automatic soft start. | | |
| Axles | Driving/steering axles with final drive at front and rear, front axle oscillating (+/-10°). | | |
| Axle drive | Four wheel drive, front wheel drive preselectable connect and disconnect. | | |
| Differential locks | Preselectable, electro hydraulically operated differential locks front and rear, with gear status indicator lights on dashboard. | | |
| Steering system | Hydrostatic steering with Load Sensing; electro hydraulic steering switch during driving, pre-selectable with options for 4 wheel, front, rear, and continuously adjustable crab steering; automatic synchronisation of wheel position. | | |
| Service brake | Hydraulic dual circuit 4 wheel multiple disk brake, in oil bath; Hillholder . | | |
| Parking brake | Spring loaded parking brake acting on rear axle, electro hydraulic release. | | |
| Engine hydraulics | Hydraulic pump 32.5 l/min, 195 bar, oil tank 34 l, standard equipment var. B11 : 1 control valve d.a.f. for rear linkage; 1 control valve s.a. for front linkage, 2 control valves (d.a.f. and d.a.) with parallel lines front and rear, 1 tank return line each for front and rear, actuation by multi-function control lever. Option: Var. C11: 1 additional control valve d.a.f. with parallel lines front and rear. | | |
| Front linkage | Axle guided, with electro hydraulic weight compensation and vibration damping , quick release system using seating locators, cat. 2, electric external control, lifting force 1,800 kg. Option: Integrated hydraulic side shift with 450 mm adjustment range (+/-225 mm). | | |
| Rear linkage | Lower link with hook end, cat. 2, electrical external control, adjustable lowering speed control, lift/pressure design vibration damping , Lifting force 2,500 kg. Option: Drawbar (in Switzerland only s.a. rear linkage) | | |
| Front PTO | Power shift PTO 1,000 rpm, counter clockwise, electro hydraulically switchable with automatic soft start, (rotational direction looking at PTO shaft end). | | |
| Rear PTO | Power shift PTO 540 and 750 rpm, switchable, clockwise, electro hydraulically switchable with automatic soft start, (rotational direction looking at PTO shaft end). | | |
| Cab | Vibration damped deluxe cab with heating and air conditioning , tool-less steering wheel adjustment, panoramic windscreen, full glass doors and hinged rear window, tinted windows, upright exhaust pipe and air intake, comfort seats in various versions, noise absorbing interior trim, cab illumination, sun shade, storage compartment, coat hook, bottle holder, radio preparation in cab roof incl. 2 speakers and aerial, wiper, windscreen washer, tool box. Option: heated windscreen and/or rearview mirror. | | |
| Gauges | Tachometer with integrated operating hours meter; fuel gauge, coolant temperature display, speedometer, cigarette lighter; Indicator light with symbols for differential locks, four wheel drive, hand brake, steering modes, fuel gauge, straight wheel alignment; clock, PTO speed front/rear. | | |
| Electric system | Battery 12V, 100 Ah, alternator 140 A, full road lighting, 2 roof lights front and 1 working light rear. | | |
| Fuel tank | Polyethylene tank, capacity 110 l. | | |
| Seat design | Longitudinally and height adjustable comfort seats with arm rest, pelvic support and tilt adjustable backrest in 3 designs: Comfort seat with cloth cover (standard) or leatherette cover, air cushioned seat with cloth cover and high backrest; Option: High backrest for comfort seat, cloth seat cover, seat belt, electr. swivel feature | | |
| Tyre options | 425/55 R17 AG tyres (standard) 440/50 R17 All Ground <i>Auxiliary wheels 7.50-18 AG</i> | 405/70 R20 AG tyres 420/65 R20 AG tyres <i>Auxiliary wheels 9.5-24 AG</i> | 275/80 R20 AG tyres narrow track 12.5 R20 MPT 80 municipal tyres 560 /45-22.5 turf tyres |
| Accessories | Mechanical or automatic trailer hitches (fixed or height adjustable, towing load up to 10,000 kg), hydr. trailer brake, air pressure brake system, Front mounting frame, hydr. top link, stereo radio with CD, rotating warning light, add. working light front or rear, Cleanfix reversing fan , rear wiper, heated windscreen or mirror, custom paint, snow chains; other options on request. | | |
| Attachments | Front end loader with single lever operation, flail mower and extension arm boom flail mower, sickle mower with grass container, snow plough, snow blower, road brush, trailer up to 10 t, rotary disc mower, side delivery belt rake, swather, seed drill; further attachments on request. | | |
| Weights | Dead weight (with standard equipment): 3,625 kg Perm. axle load front and rear: 3,800 kg Perm. gross weight: 6,000 kg | | |
| Turning radius | 3.40 m (with 4 wheel steering) | | |

Dimensions Mounty 100 V

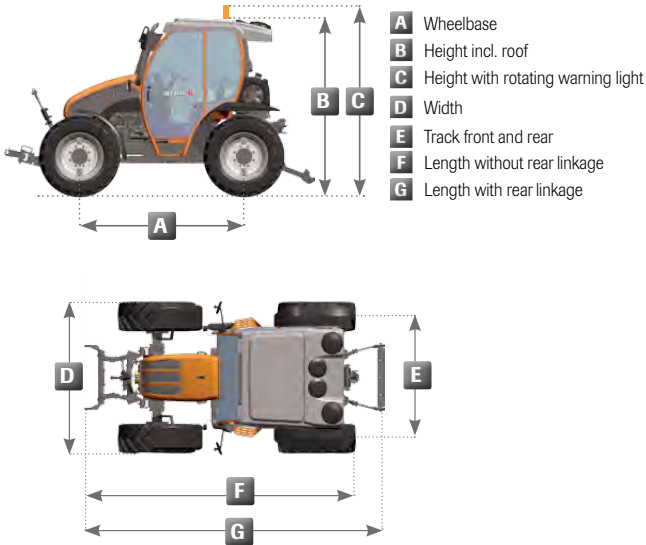

| Dimensions in mm depending on tyres | | | | | | |
|-------------------------------------|--------------------------|------------|------------|------------|----------|-------------|
| | 425/55 R17 440/50 R17 | 405/70 R20 | 420/65 R20 | 275/80 R20 | 12.5/R20 | 560/45-22.5 |
| A | 2225 | 2225 | 2225 | 2225 | 2225 | 2225 |
| B | 2260 | 2350 | 2335 | 2310 | 2335 | 2350 |
| C | 2435 | 2525 | 2510 | 2485 | 2510 | 2525 |
| D | 2130 | 2085 | 2085 | 1850 | 1950 | 2415 |
| E | 1700 | 1680 | 1680 | 1475 | 1610 | 1805 |
| F | 3740 | 3830 | 3815 | 3790 | 3815 | 3830 |
| G | 4275 | 4275 | 4275 | 4275 | 4275 | 4275 |

Outer wheel widths Mounty 100 V

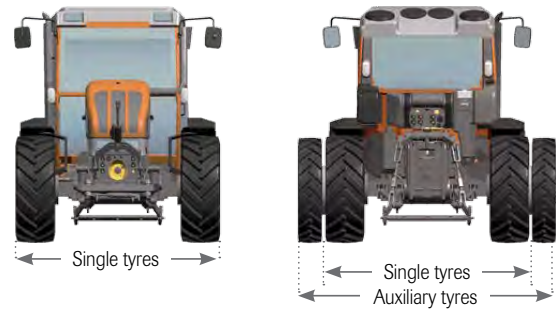

| Wheel outer width (mm) | Mounty 100 V |
|---|-----------------------------------|
| 425/55 R17 AG tyres | 2130 |
| 425/55-R17 with 7.50-18 | 2560 |
| 440/50 R17 All Ground | 2130 |
| 440/50-R17 with 7.50-18 | 2560 |
| 405/70 R20 AG tyres | 2085 |
| 405/70 R20 with 9.5 -24 | 2650 |
| 420/65 R20 AG tyres | 2085 |
| 420/65 R20 with 9.5 -24 | 2650 |
| 275/80 R20 AG tyres narrow track | 1750 tyres / 1850 axle |
| 12.5 R20 MPT 80 municipal tyres | 1950 |
| 560 /45-22.5 turf tyres | 2415 |

REFORM Mounty – Simply the best!





REFORM – your strong partner.

The acknowledged expert in municipal technology, intensive lawn care, mountain agriculture, horticulture and landscaping as well as seed drill construction since 1910. Innovative quality solutions help to preserve a livable environment. We maintain a long term, reliable partnership with our customers. REFORM is the expert for steep slopes. So

you experience best possible safety on extreme terrain. REFORM machines are distinguished by compact design, low dead weight and excellent soil protection. The tried and tested REFORM 4 wheel steering allows formidable agility with the smallest footprint. REFORM is your partner for all year round operation, offering solutions tailored to your requirements.



Illustrations may show special equipment. Typographical errors and technological changes excepted.

RW 70213/0212

Stocker-Crew
PO BOX 203, Warners Bay NSW 2282
(02) 4954 8900
sales@stockercrew.com.au
www.stockercrew.com.au

REFORM -WERKE

AGROMONT AG



REFORM



www.reform.at