

# **METRAC**

**H5 X 60 HP**

**NEW!**



The all-rounder for all applications.

**Compact. Powerful. Efficient.**

**REFORM** 

TECHNOLOGY AT ITS BEST

# Technical data Metrac H5 X

**Engine H5 X:** 4 cylinder 4 stroke turbo diesel engine Kubota V2403-M-T, 60 hp/44.0 kW according to SAE J1995 resp. 59 hp/43,3 kW according to EC 97/68 at 2700 rpm, displacement 2434 cm<sup>3</sup>, max. torque 165 Nm at 1800 rpm

**Clutch:** Single dry disc clutch for PTO gear

**Gearbox:** Hydrostatic travel drive with mechanical 2 range gear and electro hydraulic 2 level switching, inching pedal; hydrostatic control optionally automotiv or manual, electrically switchable.

**4 speed ranges:**

with 31" tyres: Off-road: 0 – 7.0 kph / 0 – 13.8 kph

Road: 0 – 18.1 kph / 0 – 36.0 kph

with 33" tyres: Off-road: 0 – 7.6 kph / 0 – 15.0 kph

Road: 0 – 19.6 kph / 0 – 39.0 kph

**Axle drive:** Four wheel drive, two wheel drive switchable

**Axles:** Steering drive axles with final drive at front and rear, front axle swivelling

**Differential locks:** Pre selectable, manually operated differential locks front and rear, with status indicator lights on dashboard

**Steering:** Hydrostatic steering with Load Sensing; electro-hydraulic all wheel steering, switchable to front, rear, and crab steering on the move

**PTO:** Power-shift PTO front and rear 540 rpm, front counter clockwise, rear clockwise, electro hydraulic switchable with automatic soft start (direction of rotation: looking at PTO shaft end).

**Service brake:** Hydraulic 2 circuit, 4 wheel power brake

**Parking brake:** Mechanical parking brake for rear wheels

**Tyres:** Low pressure Terra, AS, or turf tyres 31x15.50-15

Option: 33x15.50-15 Terra tyres

**Hydraulic system:** Hydraulic pump 29.7 l/min, 195 bar, Oil tank: 13 l, max. 10 push on couplings on the front and 8 at the rear

**Front lift:** Angle swing lift with electro-hydraulic weight compensation, hydraulic vibration damping, Cat. I, integrated hydraulic lateral displacement

with 400 mm (± 200 mm) travel range; quick release system using seating locators; electrical external control; lifting force 1300 kg

**Electrical system:** 12 V; generator 70 A; battery 90 Ah; height adjustable headlights, 2 indicators front, brake, tail and indicator lights at rear

**Fuel tank:** Polyethylene tank, capacity 63 l

**Cab:** Vibration damped driver rollover protection frame with roof, tinted windscreen, right window, interior mirror, bottle holder, ergonomic seat with pelvic support.

Optional: Closed cabin with heating, air-conditioning

**Turning radius:** 3.55 m (with all-wheel steering)

**Weights:** Dead weight with standard equipment: 1890 kg, max. perm. axle load front and rear: 1800 kg, gross vehicle weight: 3000 kg

**Dashboard:** Tachometer with integrated operating hours meter, fuel gauge, remote thermometer, indicator lights with symbols, digital travel display, cigarette lighter, temperature display for hydrostatic travel drive

**Auxiliary tyres with quick release:** 6.50-16 AS for 31x15.50-15, 7.50-16 AS for 33x15.50-15

**Additional equipment:** 3-point rear lifting gear with retaining balls Cat. I and II, lifting force 1200 kg, electrical external control, optional with vibration damping; lifting gear switch front/rear, trailer hitch, rotating warning light, radio, working light, snow chains, heated fuel filter, hydraulic top link, swivel seat, air cushioned comfort seat, cabin with heating, roof ventilation, air conditioning

**Tools:** Twin blade mower, rotary disc mower, zero grazing mower, side delivery belt rake, front collecting fork, dump bucket, flail mower, twin blade front and/or side mower, sickle mower (with side or rear ejection), suction container with or without high discharge, side arm flail mower, front end loader, road sweeper, snow plough, snow blower, self loading salt spreader. Further equipment on request.

## Dimensions with 31" tyres (mm)

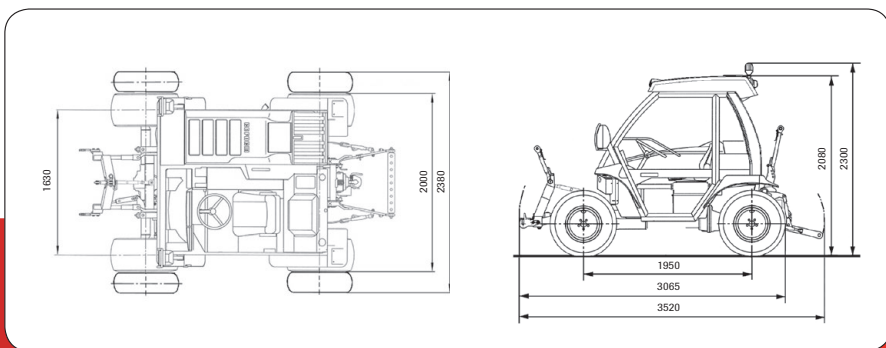

Your Reform partner

### REFORM-WERKE

Bauer & Co Gesellschaft m.b.H.  
 Haidestrasse 40, A-4600 Wels  
 FN 139380 x, Landesgericht Wels  
 Phone 0043 / 7242 / 232 - 0  
 Fax 0043 / 7242 / 232 - 4  
 www.reform.at  
 E-mail: info@reform.at

### AGROMONT AG

Postfach 142  
 Boesch 1  
 CH-6331 Hünenberg  
 Phone 0041 / 41 / 784 20 20  
 Fax 0041 / 41 / 784 20 22  
 www.agromont.ch  
 E-mail: info@agromont.ch

