

METRAC

H4 X 49 HP



NEW!



The small one with the big heart.
Strong. Robust. Effective.

REFORM 

SINCE 1910

TECHNOLOGY AT ITS BEST

Technical specifications Metrac H4 X

Engine H4 X: 4 cylinder 4 stroke diesel engine, naturally aspirated, Kubota V2403-M, 36 kW (49 hp) at 2700 rpm, displacement 2434 cm³, water-cooled, max. torque 156 Nm at 1425 rpm.

Clutch: Single dry disc clutch for PTO drive

Gearbox: Hydrostatic drive with mechanical 2 stage gear and electro-hydraulic 2 level switching, inch pedal, hydrostatic control optionally automotive or manual, electrically switchable. 4 speed ranges:

with 31" tyres:

Field: 0 – 7.0 kph / 0 – 13.8 kph

Road: 0 – 18.1 kph / 0 – 36.0 kph

with 33" tyres:

Field: 0 – 7.6 kph / 0 – 15.0 kph

Road: 0 – 19.6 kph / 0 – 39.0 kph

Axle drive: 4-wheel drive, front-wheel drive switchable.

Axles: Steering drive axles with final drive at front and rear, front axle oscillating.

Differential locks: Preselectable, manually operated differential locks front and rear, with switch status indicator lights on dashboard.

Steering: Hydrostatic steering with Load Sensing; electro-hydraulic 4-wheel steering, switchable to front, rear, and crab steering during driving

PTO: Power-shift PTO front and rear 540 rpm, front counter-clockwise, rear clockwise (direction of rotation: looking at PTO shaft end).

Service brake: Hydr. dual circuit 4 wheel power brake.

Parking brake: Mechanical parking brake, acting on rear axle service brake.

Tyres: Low-pressure Terra, AG or turf tyres 31x15.50-15
Option: 33x15.50-15 Terra tyres

Hydraulic system: Hydraulic pump 29.7 l/min, 195 bar, oil tank: 13 l, max. 10 trailer couplings in front and 8 at rear

Front linkage: Angle swing linkage, with electro-hydraulic weight compensation, quick release system using seating locators, cat. I, electric external control, lifting force 1300 kg; Option: vibration damping, lateral displacement

Electrical system: 12 V; alternator 70 A; battery 90 Ah; height-adjustable headlights, 2 indicators front, brake, tail and indicator lights at rear

Fuel tank: Polyethylene tank, capacity 63 l.

Cab: Vibration-damped driver rollover protection frame with roof, tinted windscreen, right side window, interior mirror, bottle holder, comfort seats in several versions.

Option: closed deluxe cab with heating, air-conditioning.

Turning radius: 3.55 m (with 4 wheel steering)

Weights: Dead weight (with standard equipment): 1870 kg; max. perm. axle load front and rear: 1800 kg; gross weight: 3000 kg

Dashboard: Tachometer with integrated operating hours meter, fuel gauge, temperature gauge, indicator lights with symbols (e.g. for differential locks), digital travel speed display, cigarette lighter, temperature display for hydrostatic drive

Auxiliary tyres with quick release:

6.50-16 AS for 31x15.50-15, 7.50-16 AS for 33x15.50-15

Accessories: Rear 3 point linkage with moving lower links, retaining balls, cat. I and II, lifting force 1200 kg, electrical external control, optionally with vibration damping, trailer hitch, rotating warning light, radio, working light, snow chains, hydraulic top link, swivel seat, cab with heating, roof ventilation, air conditioning

Attachments: Twin blade mower, rotary disc mower, side delivery belt rake, front collecting fork, dump bucket, front and/or side twin blade mower, sickle mower, flail mower, snow plough. Further tools on request.

Dimensions with 31" tyres (mm)

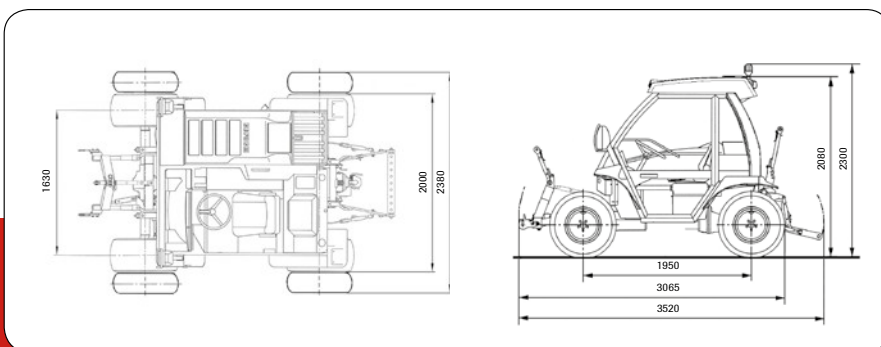

Your Reform partner

REFORM-WERKE

Bauer & Co Gesellschaft m.b.H.
Haidestraße 40, A-4600 Wels
FN 139380 x, Landesgericht Wels
Tel. 0043 / 7242 / 232 - 0
Fax 0043 / 7242 / 232 - 4
www.reform.at
E-Mail: info@reform.at

AGROMONT AG

Postfach 142
Bösch 1
CH-6331 Hünenberg
Tel. 0041 / 41 / 784 20 20
Fax 0041 / 41 / 784 20 22
www.agromont.ch
E-Mail: info@agromont.ch

