

METRAC

G5 X 60 HP

NEW!



The all-rounder for all applications.

Compact. Powerful. Efficient.

REFORM 

TECHNOLOGY AT ITS BEST

Technical data Metrac G5 X

Engine G5 X: 4 cylinder 4 stroke turbo diesel engine Kubota V2403-M-T, 60 hp/44.0 kW according to SAE J1995 resp. 59 hp/43,3 kW according to EC 97/68 at 2700 rpm, displacement 2434 cm³, max. torque 165 Nm at 1800 rpm

Clutch: Single disc dry clutch for travel drive, multi disc clutch for PTO drive

Gearbox: Group reverse gearbox with 8 F / 8 R gears, speed change and reverse gears synchronised, smooth shifting group gearbox;

2.3 – 27.3 kph with 31" tyres

2.4 – 29.5 kph with 33" tyres

Option: Creep speed version

12 F / 12 R gears,

1.04 – 27.3 kph with 31" tyres

1.12 – 29.5 kph with 33" tyres

Axle drive: Four wheel drive, two wheel drive switchable

Axles: Steering drive axles with final drive at front and rear, front axle self-aligned

Differential locks: Pre selectable, manually operated differential locks front and rear, with status indicator lights on dashboard

Steering: Hydrostatic steering with Load Sensing; electro-hydraulic all-wheel steering, switchable to front, rear, and crab steering on the move

PTO: Power-shift PTO front 540 rpm, rear 540 or 750 rpm, front counter clockwise, rear clockwise, electro hydraulic switchable with automatic soft start (direction of rotation: looking at PTO shaft end).

Service brake: Hydraulic 2 circuit, 4 wheel power brake

Parking brake: Mechanical parking brake for rear wheels

Tyres: Low pressure Terra, AS, or turf tyres 31x15.50-15

Option: 33x15.50-15 Terra tyres

Hydraulic system: Hydraulic pump 29.7 l/min, 195 bar, oil tank: 13 l, max. 10 push on couplings on the front and 8 at the rear

Front lift: Angle swing lift with electro-hydraulic weight compensation, Cat. I, integrated hydraulic lateral displacement with 400 mm (\pm 200 mm) travel range; quick release system using seating locators; electrical external control; lifting force 1300 kg; option: vibration damping

Electrical system: 12 V; generator 70 A; battery 90 Ah; height adjustable headlights, 2 indicators front, brake, tail and indicator lights at rear

Fuel tank: Polyethylene tank, capacity 63 l

Cab: Vibration damped driver rollover protection frame with roof, tinted wind-screen, right window, interior mirror, bottle holder, ergonomic seat with pelvic support; Optional: closed cabin with heating, air-conditioning

Turning radius: 3.55 m (with all-wheel steering)

Weights: Dead weight with standard equipment: 1870 kg, max. perm. axle load front and rear: 1800 kg, gross vehicle weight: 3000 kg

Dashboard: Tachometer with integrated operating hours meter, fuel gauge, remote thermometer, indicator lights with symbols, cigarette lighter, Optional: digital travel speed display,

Auxiliary tyres with quick release:

6.50-16 AS for 31x15.50-15, 7.50-16 AS for 33x15.50-15

Additional equipment: Rear 3 point linkage with retaining balls Cat. I and II, lifting force 1200 kg, electrical external control, optional with vibration damping; lifting gear switch front/rear, trailer hitch, rotating warning light, radio, working light, snow chains, heated fuel filter, hydraulic top link, swivel seat, air cushioned comfort seat, cabin with heating, roof ventilation, air conditioning

Tools: Twin blade mower, rotary disc mower, zero grazing mower, side delivery belt rake, front collecting fork, dump bucket, flail mower, twin blade front and/or side mower, sickle mower (with side or rear ejection), suction container with or without high discharge, side arm flail mower, front end loader, road sweeper, snow plough, snow blower, self loading salt spreader. Further equipment on request.

Dimensions with 31" tyres (mm)

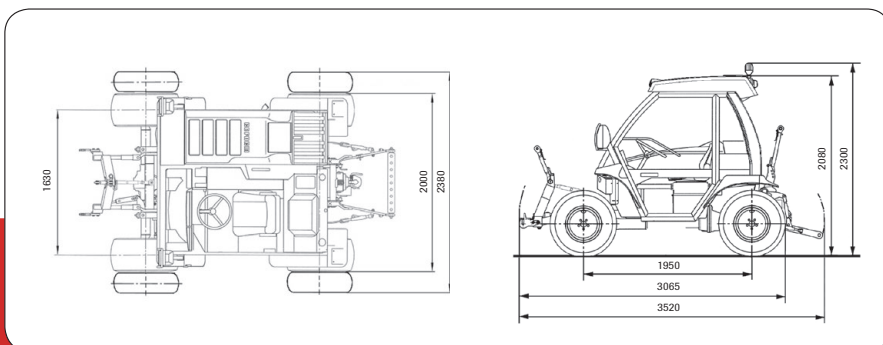

Your Reform partner

REFORM-WERKE

Bauer & Co Gesellschaft m.b.H.
Haidestrasse 40, A-4600 Wels
FN 139380 x, Landesgericht Wels
Phone 0043 / 7242 / 232 - 0
Fax 0043 / 7242 / 232 - 4
www.reform.at
E-mail: info@reform.at

AGROMONT AG

Postfach 142
Boesch 1
CH-6331 Hünenberg
Phone 0041 / 41 / 784 20 20
Fax 0041 / 41 / 784 20 22
www.agromont.ch
E-mail: info@agromont.ch