

METRAC
G3 X 44 HP



**The comfortable mountain companion.
Robust. Compact. Economical.**

REFORM 
SINCE 1910

TECHNOLOGY AT ITS BEST

REFORM Metrac G3 X

The comfortable mountain companion.

Robustly ride up and down the hills

The entry level to the X series has never been as compact as with the G3 X.

The characteristic feature of the X series is the final drives, which protect and support the drive train. This reduces wear and increases the service life of the vehicle. The Metrac G3 X can optionally be equipped with a closed cab, heating and defroster, making the machine fit for use in poor weather conditions.

The benefits at a glance:

- Robust yet highly efficient design
- Powerful technology
- Maximum terrain mobility
- Optionally with closed cab
- Front linkage with hydraulic weight compensation
- 4 steering modes for unbeatable manoeuvrability
- Switchable 4 wheel drive
- Low centre of gravity
- Large footprint
- Highest soil protection
- Low dead weight

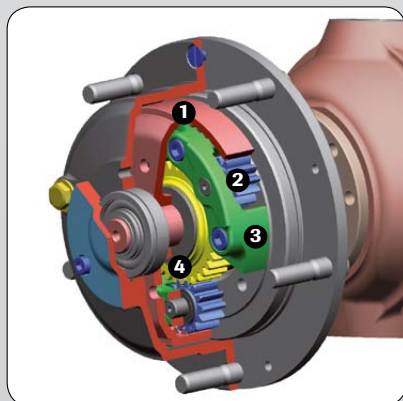

Long service life

Robust driving/steering axles with planet gear final drives support and protect the drive train. The drive shaft drives the internal gear (1). Via the planet gears (2) and the fixed internal sun gear (4), a lower rotational speed is induced in the planet gear carrier (3), which is bolted to the wheel hub. The transferable torque is increased only here. This means, the forces acting on the drive shaft are lower.

Perfect attachment areas

The front and rear linkages ensure optimal daily use.

The front linkage (cat. 1) with 900 kg lifting force can be equipped with a hydraulic top link. The optional rear linkage with moving lower links has a lifting force of 950 kg. The hydraulic weight compensation makes the device even more capable on slopes.





To see and be seen

The Metrac G3 X can be equipped with auxiliary lights and a rotating warning light. For optimal view in twilight and at night.



Tilt adjustable steering column.

Comfort with a capital 'C'

The driver rollover protection frame with roof, tinted windscreen, right and left side windows, and a rear window provides large head clearance and moving space. The Metrac G3 X can optionally be equipped with a closed cab, including heating and defroster. Higher comfort in all locations and under all conditions.

A spacious workplace

Take your seat in the generously dimensioned deluxe cab and feel instantly at home. All controls are in easy reach and ergonomically arranged in functional groups.



Technical data Metrac G3 X

Engine G3 X: 4 cylinder 4 stroke diesel engine, Kubota V 2003 M EU-32, stage 3A, 32.1 kW (44 hp) at 2800 rpm, displacement 1999 cm³, water cooled. Torque 128.4 Nm at 1600 rpm.

Clutch: Single disc dry clutch for travel drive and rear PTO (via clutch pedal), multi disc clutch for front PTO drive (hand lever operated).

Gearbox: Shuttle gearbox with 8 forward and 8 reverse gears Speed: 2.3 – 23.0 kph.

Axles: Driving/steering axles with final drives front and rear, front axle oscillating.

Axle drive: Four wheel drive, front-wheel drive switchable.

Differential locks: Self-locking differential front, manual differential lock rear.

Steering: Hydrostatic steering with Load Sensing; electro-hydraulic steering switch during driving, preselectable with options for 4 wheel, front, rear and continuously adjustable crab steering; autom. synchronisation of wheel position.

Service brake: Hydr. dual circuit 4 wheel power brake.

Parking brake: Mechanical parking brake and steering brake mechanism acting on front wheels.

Engine hydraulics: Hydraulic pump 26.6 l/min, 180 bar, oil tank 8 l, standard equipment var. B1: 1 control valve each for front and rear linkage, 1 control valve d.a.f. with parallel lines front and rear; Options: Var. C1: 1 additional control valve d.a.f. with parallel lines front and rear (max. 4 trailer couplings front and 4 rear).

Front linkage: Front 3 point linkage with hydraulic weight compensation, quick release system via seating locators, top link mount, lifting force max. 900 kg.

Rear linkage (option): Rear 3 point linkage with movable lower links, retaining balls cat. 1 + 2, single acting cylinder, lowering speed control, lifting force 950 kg, mechanical weight compensation.

Options: Lower links with hook ends cat. 1 + 2, double acting cylinder (lift/pressure), drawbar.

PTO: Power shiftable front PTO: 540 rpm, counterclockwise; Rear PTO: 540 rpm, clockwise; (rotational direction looking at PTO shaft end).

Cab: Driver rollover protection frame with roof and tinted windscreen, side window right and left, rear window, tilt adjustable steering column, comfort seat, wiper with windscreen washer, cable lead-through for attachments. Option: Closed cab with door, sliding window, heating and defroster.

Gauges: Tachometer with integrated operating hours meter, fuel gauge, remote thermometer, indicator for straight wheel alignment, various indicator lights with symbols.

Electric system: Battery 12V, 60 Ah, alternator 45 A, full road lighting, complete. Option: Auxiliary lights front on roof, 1 working light rear, rotating warning light.

Fuel tank: PE tank, capacity 35 l.

Seat designs: Comfort seat with leatherette cover, pelvic support, longitudinally and height adjustable, tilt-adjustable backrest; Options: High backrest, protective cloth cover, arm rest, seat belt.

Wheel options:

Standard: 29x13.50-15 Terra tyres

Options: Auxiliary wheels 5.00-16 AG with quick release,

Mounting parts for auxiliary wheels on 2nd axle

Accessories: Mechanical or automatic trailer hitches (mountable in different heights), hydraulic front top link, top link elevation; further options on request.

Attachments: Twin blade mower, rotary disc mower, side delivery belt rake, front collecting fork, flail mower, dump bucket, snow plough; further attachments on request.

Weights:

Dead weight: 1,490 kg

Perm. axle load front: 1,600 kg

Perm. axle load rear: 1,600 kg

Perm. gross weight: 2,500 kg

Turning radius: 3.20 m

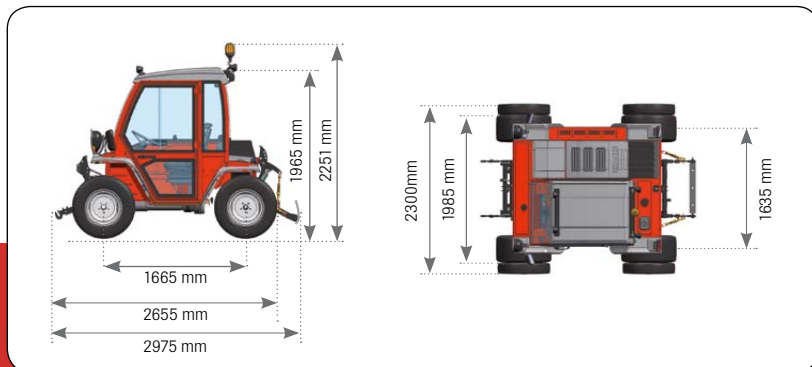

Your Reform partner

REFORM-WERKE

Bauer & Co Gesellschaft m.b.H.
Haidestraße 40, A-4600 Wels
FN 139380 x, Landesgericht Wels
Tel. 0043 / 7242 / 232 - 0
Fax 0043 / 7242 / 232 - 4
www.reform.at
E-Mail: info@reform.at

AGROMONT AG

Postfach 142
Bösch 1
CH-6331 Hünenberg
Tel. 0041 / 41 / 784 20 20
Fax 0041 / 41 / 784 20 22
www.agromont.ch
E-Mail: info@agromont.ch



www.reform.at